



Electric adjustable Pedestals

Electric adjustable height pedestal system uses a 2-7/8" or 3.4" post, 9" or 12" bases, designed for electric up / down.



PN 195410-LASTWOS	10.3"-12.28"
PN 196501-LAWOS	12"-15.75"
PN 198501-LAWOS	12"-15.745"

Feature choices

Swivel Slide

Locking & non-locking swivels, & slide/ swivels. Use machined bushings for reduced wobble. Slides provide 5" of smooth travel using center rail design.

Post

Options mimic gas rise Heavy Duty and Off-shore sizes. Rated to 675 lbs. Continuous use at 300 lbs.+, H31 tested. Uses a stop limiter. No wobble.

Base

Offered in both thru-deck and above-deck options depending of hieght and travel required. Available in 9" and 12" bases.

Options

Power required is 12V/24V, 5A for the reverse polarity actuator. Uses a double throw momentary switch (not included).

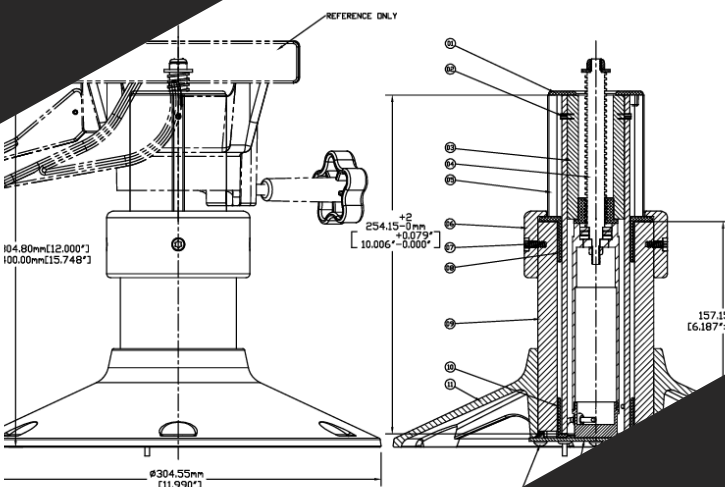

Why Choose Us?

Our goal is to provide a premium product that solves common complaints of boaters. Strong, Stable, Smooth, Quiet, Convenient, this is how we:

DELIVER THE EXPERIENCE YOUR BRAND DESERVES.

- ✓ Rated to 675 lbs.
- ✓ Location freedom for switch.
- ✓ Wobble free with stop limiter.
- ✓ Responsive Service

Contact Us

